

**P**recision **F**iltration **P**roducts

YOUR ONE  FOR FILTERS

# Oil Mist Eliminators



- *Protecting the Environment*
- *Protecting your Equipment*
- *Filtration*
- *Separation*

# Eliminate Visible Emissions

Around the world, PFP works with engineers to manufacture and deliver oil mist solutions for the equipment that powers our lives. From gas and steam turbines to compressors and reciprocating engines, the Oil Mist Eliminators are found in the most challenging applications.

For over 40 years, we have embraced the ideal of industrial growth while advocating responsibility for our environment. We are committed to providing systems that protect mission critical machinery while safeguarding the surrounding environment.



**Alstom GT11NM Gas Turbine**  
*Inset: Hazardous Oil Mist Emissions from Previous Electrostatic Precipitator. After: Clean and Safe Work Environment with a Oil Mist Eliminator.*



**GE LM2500 Gas Turbine**  
Stainless Steel Vacuum Assisted Oil Mist Eliminator.

## Design Features and Specifications

- 99.97% efficient for 0.3 micron oil mist
- Designed to eliminate visible emissions
- Extensive flow ranges available
- Carbon Steel and Stainless Steel construction options
- Systems can be built to ATEX, ASME and PED standards
- Application specific filtration media and coating solutions
- Automated and manual vacuum/pressure control selections
- Custom mounting configurations for field retro-fits

**Precision Filtration Products** · P.O. Box 218 Pennsburg, PA 18073

Phone: 215-679-6645 · Fax: 215-679-6648 · [sales@precisionfiltration.com](mailto:sales@precisionfiltration.com) · [www.precisionfiltration.com](http://www.precisionfiltration.com)

# Turbine Applications

## Purpose & Benefits

The Vacuum Assisted Oil Mist Eliminators are designed to eliminate visible oil mist emissions vented from turbine and generator lube oil consoles. These eliminators capture and coalesce oily aerosol mist and incorporate a draining mechanism to recycle oil back to the console or a separate storage area. In addition to reducing operating costs, mist eliminators mitigate potential health, safety and environmental hazards associated with venting the mist directly into the surrounding environment. A variety of manual or automated control options are available to precisely regulate the vacuum or pressure level at critical seal points along the drive train. This control prevents excess system pressure, a primary cause for seal leakage at the bearings and shaft seals.

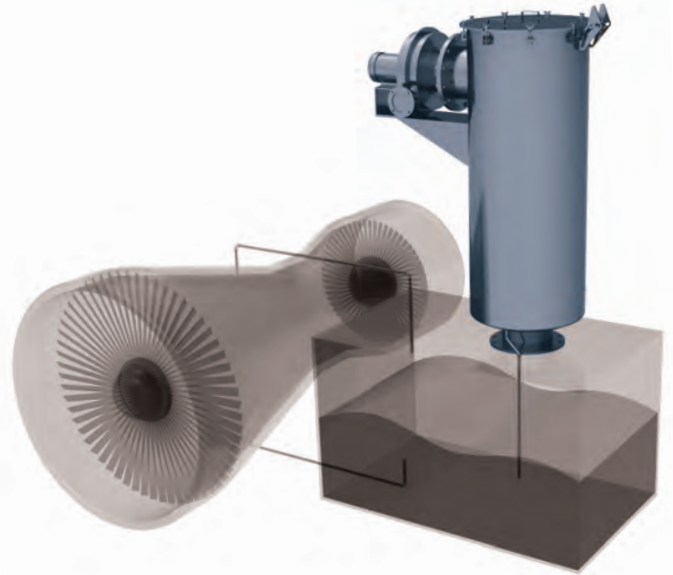

## Solutions for

Alstom, Elliott, GE, Hitachi, Kawasaki, Man Turbo, OPRA, Pratt & Whitney, Rolls-Royce, Siemens and more

# Reciprocating Engines & Gen-Sets

## Purpose & Benefits

For both land and marine based engine applications, excessive pressure in the crankcase diminishes performance, causes oil leaks and pushes harmful emissions to the surrounding environment. The Vacuum Assisted Oil Mist Eliminators are engineered to capture vented crankcase emissions and maintain crankcase pressure levels in accordance with the engine manufacturer's specifications. These eliminators reduce the potential for oil leaks caused by excess pressure and eliminate harmful oil mist from engine rooms for improved health and safety. Because blow-by increases with engine wear, systems incorporate manual, automatic, and re-circulating devices to effectively control crankcase pressure over the engine's life span.

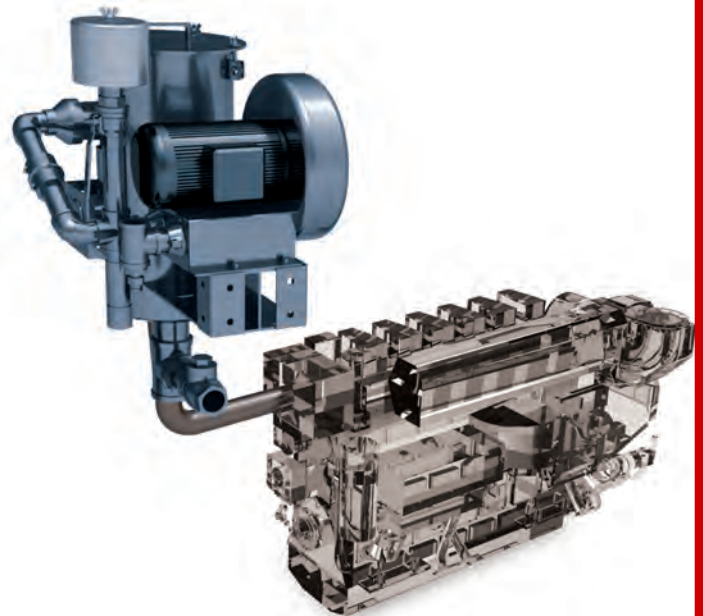

## Solutions for

Caterpillar, Fairbanks Morse, Guascor, Jenbacher, Man Diesel, MTU, Waukesha, Wartsila and more

# Static Oil Mist Eliminators

The Static Oil Mist Eliminators are effective at capturing and removing visible oil mist emissions from the lube oil consoles for a variety of equipment including compressors and turbines. Static assemblies operate without any additional air/power source and are used in applications that can tolerate some level of positive pressure. These products generally require minimal installation modifications and are available in a variety of configurations, connection styles and sizes to meet application specific demands.

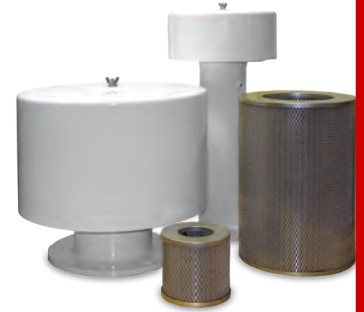

## Oil Mist Solutions for Your Specific Applications



**Shin Nippon Steam Turbine**  
Stainless Steel Vacuum Assisted Oil Mist Eliminator

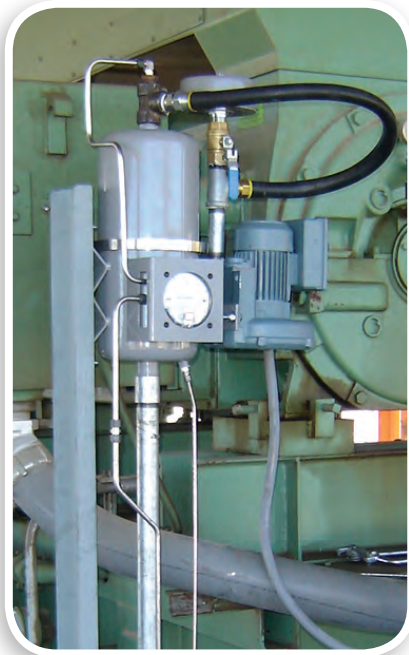

**Cooper TA11000 Compressor**  
Vacuum Assisted Oil Mist Eliminator

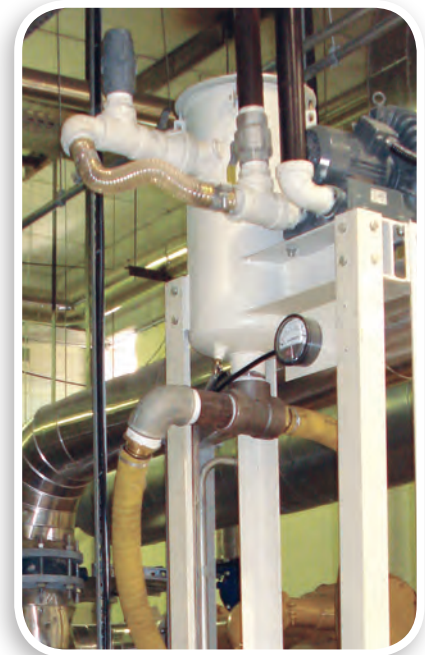

**Caterpillar G3520 Engine/Gen-Set**  
Landfill Gas to Energy Application  
Vacuum Assisted Oil Mist Eliminator