

Precision Filtration Products

YOUR ONE  FOR FILTERS

MODEL P22-Vacuum

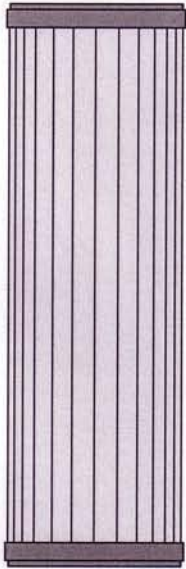

321-3239K5

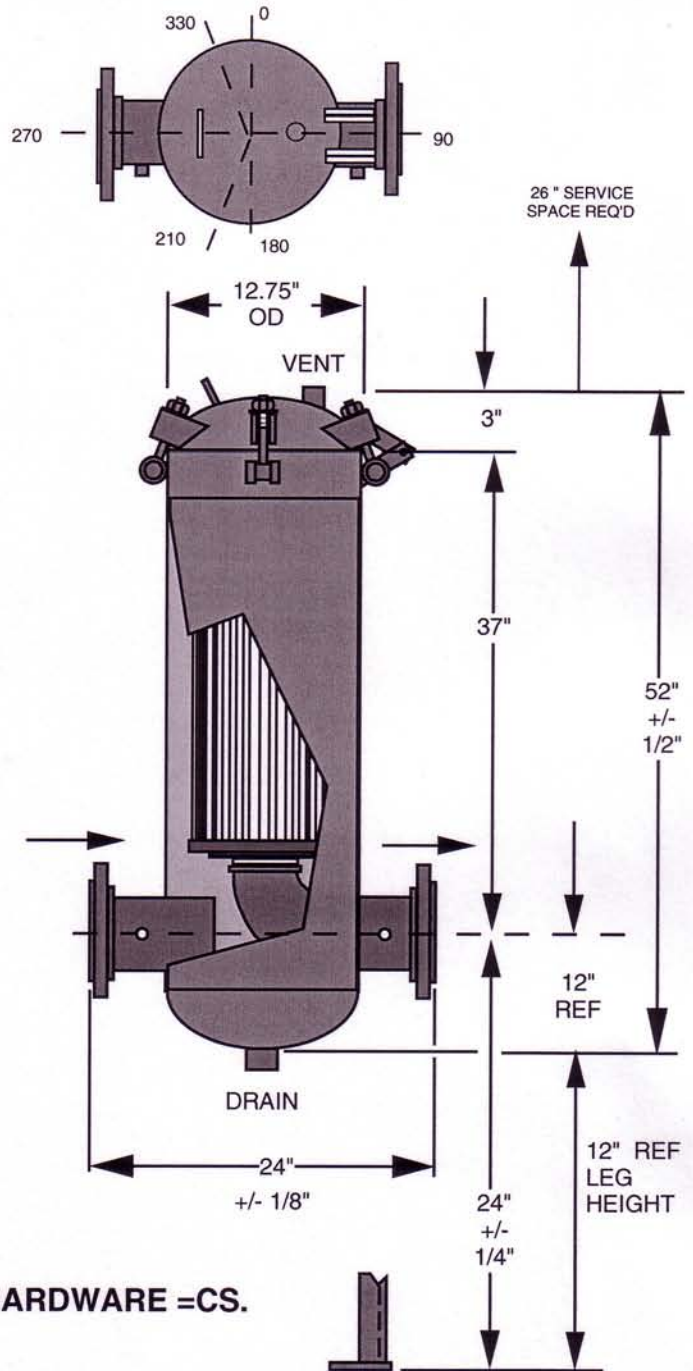

FULL VACUUM

175 PSIG @ -20 TO +200 F DESIGN

TP 304 SS CONSTRUCTION, EXCEPT EXT HARDWARE =CS.

O RING SEAL - BUNA N

FINISH: NONE (HI HEAT ALUM ON CS)

1/2" DRAIN, 1/2" VENT, 1/4" GAGE CONN (3000# NPT COUPL & PLUG)

6" - RFSO CL 150 ANSI FLANGE INLET & OUTLET

(3) CS (2-1/2") ANGLE LEGS WITH 1/4" TK X 3" SQ LEG PADS PROVIDED.

30 SQ FT FILTERING AREA

APPROX WEIGHT - 300 LBS

MAJOR MATERIAL:

SHELL & HEADS - SCH STD	SA 312TP304/304L
FLANGES - CL 150 ANSI	SA 182F304/304L
6" CONN - SCH 40	SA 312TP304/304L
COUPLINGS - 3000# HALF	SA 182F304/304L