

FB08 Single Bag Housing

The FB08 Single Series of Liquid Bag Housings offer two depths, a 15" and a 30" housing depending upon the needed surface area and volume of fluid to be filtered.

FEATURES

- **Carbon, 304, or 316 stainless steel material**
- **150 PSI pressure rating**
- **Low pressure drop**
- **Quick swing closure with eye nuts**
- **Viton seals - lid & basket**
- **Differential, drain, and vent ports**
- **Adjustable support legs**
- **316 stainless steel strainer basket**
- **2-part epoxy finish on carbon vessels**

Our FB08 series effectively removes dirt, pipe scale, and other contaminants from process liquids such as water, chemical, and petroleum products. Quality construction and design assure protection for all down-stream equipment.



VESSEL CONSTRUCTION

Our FB08 single vessels are designed for operating up to 150 PSI at 300 degrees Fahrenheit. The housing design provides a large sump area at the bottom of the basket for particulate accumulation. This design utilizes the filter more efficiently and prolongs the element life.

The **316 S.S. basket** seals onto a viton o-ring to eliminate particulate bypass between the basket and seat. Optional **mesh-lined strainer baskets** and **o-rings** are available. Please refer to their individual brochures in our liquid catalog.

A **vent** in the housing lid and a **drain port** in the housing speed evacuation and filling. **Gauge ports** are located on the body of the housing to install gauges for monitoring the differential pressure across the bag. Permanently piped housings are opened with simple tools without disturbing the piping. **Swing bolts** with eye-nuts allow easy opening and closing of the swing-lid. No need to remove any hardware.

As a standard finish, all vessels are blast cleaned and painted inside and out with a **2-part epoxy**. Stainless steel vessels are supplied with a satin finish.

**Style 'A'
BOTTOM OUTLET**

**Style 'B'
SIDE OUTLET**

**Style 'C'
BOTTOM OUTLET 90°**

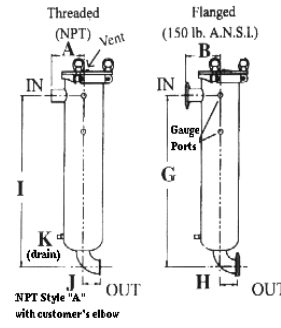
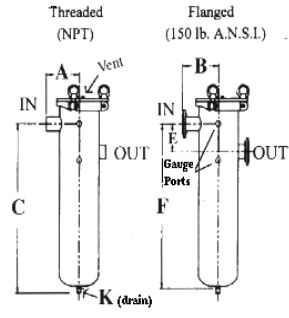
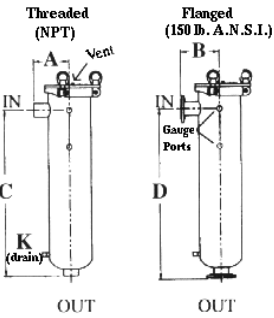

All dimensions are approximate...

Pipe Size	Pipe Size											wt.
	A	B	C	D	E	F	G	H	I	J	K	
2	5.3	6.7	24.7	25.9	7.0	24.7	26.2	3.4	25.7	2.3	1	105-125# skid wt.
3	5.4	7.1	24.7	26.5	7.0	24.7	26.5	5.0	26.3	3.1		125-145# skid wt.
4	5.4	7.1	24.7	26.6	7.0	24.7	29.1	6.3	26.9	3.8		145-175# skid wt.

Pipe Size	Pipe Size											wt.
	A	B	C	D	E	F	G	H	I	J	K	
2	5.3	6.7	36.2	37.4	7.0	36.2	37.7	3.4	37.2	2.3	1	125-145# skid wt.
3	5.4	7.1	36.2	38.0	7.0	36.2	39.2	5.0	38.7	3.1		145-175# skid wt.
4	5.4	7.1	36.2	38.1	7.0	36.2	40.6	6.3	38.9	3.8		175-200# skid wt.

Adjustable support legs have 12" bolt circle and a bolt circle and a 16" height adjustment.

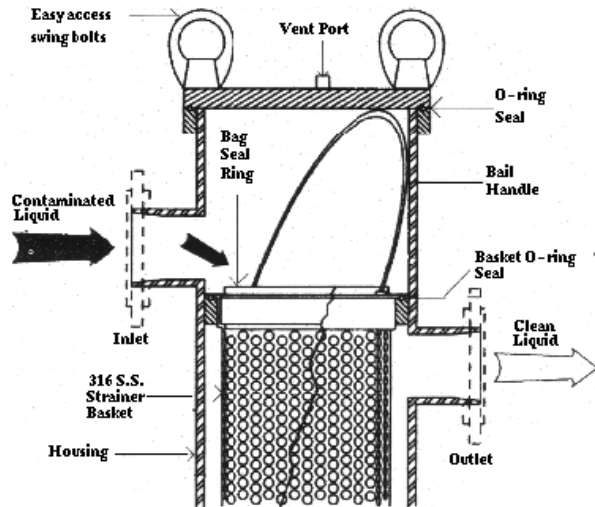

HOUSING OPERATION:

Unfiltered liquid enters the housing above the filter bag or strainer basket; flows down into the housing; and continues through the element. Solids are trapped inside the filter bag or strainer and easily removed when the housing is serviced. Our standard o-ring seal between the basket and the housing ensures a positive seal to prevent bypass.

Basket data for FB08 with flow rates to 220 gpm

Depth (inches)	Nominal Diameter (inches)	Surface Area (sq. ft.)	Volume (cu. in.)
15	6.7	2.3	500
30	6.7	4.4	1000

Building a Part Number

FB08	15	2	N	A	C	15
Housing Model #	Basket Size (in.)	Conn. Size (in.)	Conn Type	Outlet Location	Material	PSI
FB08	15 (#1)	2	NPT=N	Style=A	Carbon=C	150 = 15
	30 (#2)	3	FLANGE = F	B	304SS = 4	
		4		C	316SS = 6	

SPECIFICATIONS

Housing lid has a 3-bolt swing closure with a vent port. Connections are () inch (NPT)(FLG) with a (side inlet and bottom outlet)(side inlet and side outlet)(side inlet and 90 degree bottom outlet). Housing is supplied with two differential pressure ports to measure the differential pressure across the filter bag. A two-part epoxy finish is applied on the carbon steel vessels to maximize the life of the housing; stainless steel vessels are supplied with a satin finish. Basket material is constructed of 316 stainless steel with 9/64" perforations to act as a strainer or to accept a #1 or #2 size liquid bag. Basket seals onto a Viton o-ring in the basket support. Adjustable tripod leg assembly is supplied with housing. Vessels are rated at a 150 pounds per square inch design.