

Carbon and Clay Treater Housings

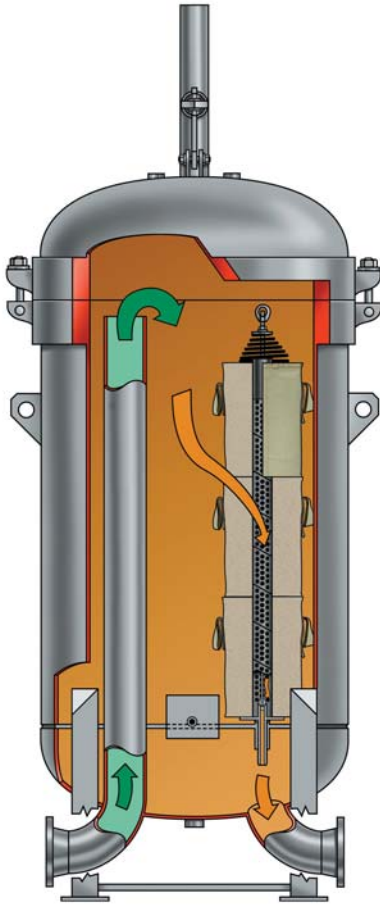

STANDARD HOUSING DESIGN

- Welded carbon steel construction
- ASME Code, Section VIII construction, stamped and certified
- Design pressure: 150 psi @ 250°F
- Inlet and outlet permanently marked
- Interior: Epoxy coated
- Exterior: Prime coated
- Removable cartridge mounting post
- Swing bolt closure
- Buna-N closure gasket
- Hydraulic headlift

NPT CONNECTIONS

- 1/4" differential pressure gauge
- 3/4" pressure relief valve and vent
- 2" main drain
- 1 1/2" side drain

OPTIONS

- Automatic air eliminator
- Differential pressure gauge
- Pressure relief valve
- Sampling probe
- Cartridge hoist assembly
- Working platform, ladder and handrails on 42" (1067 mm) OD and larger housings

DATA

| MODEL NUMBER | LIQUID VOLUME | | REQUIRED CARTRIDGES | DRY WEIGHT | |
|--------------|---------------|-------|---------------------|------------|------|
| | gals. | ltrs. | | lbs. | kgs. |
| 13F3-C | 288 | 1090 | 39 | 1913 | 868 |
| 24F3-C | 456 | 2067 | 72 | 3250 | 1474 |
| 31F3-C | 702 | 2657 | 93 | 4459 | 2023 |
| 40F3-C | 874 | 3308 | 120 | 5380 | 2440 |
| 50F3-C | 1167 | 4417 | 150 | 6976 | 3164 |
| 60F3-C | 1442 | 5458 | 180 | 8298 | 3764 |
| 67F3-C | 1570 | 5942 | 201 | 9602 | 4355 |

Weights and volumes are approximate.

Due to our continuing program of improvement, specifications are subject to change without notice.

Carbon and Clay Treater Housings

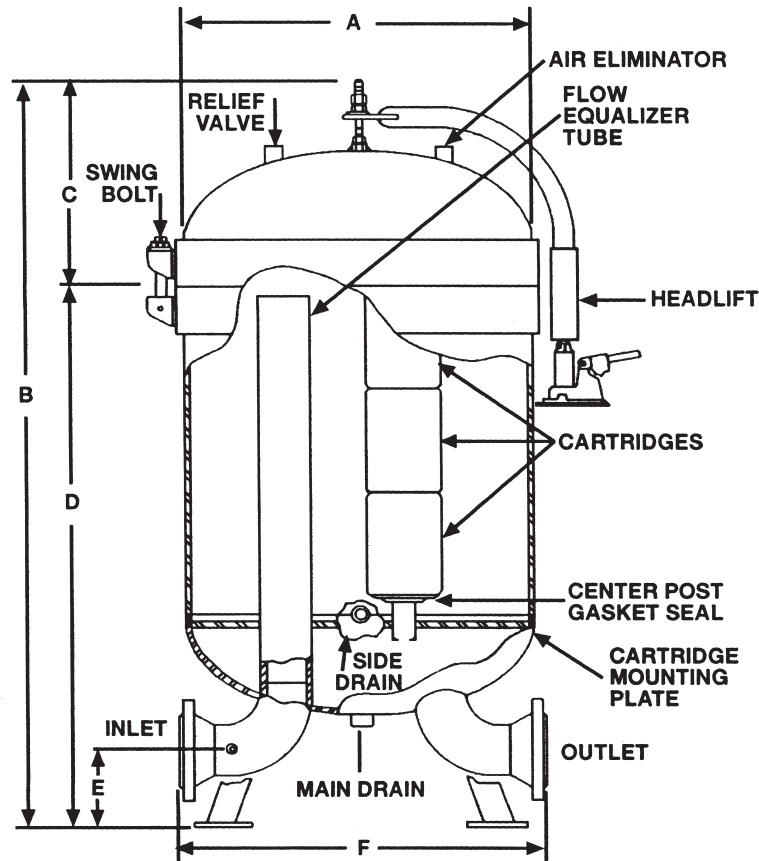

DIMENSIONS

| MODEL NUMBER | FLANGED INLET/OUTLET CONNECTIONS | | DIMENSIONS | | | | | | | | | | | | ANCHOR BOLT | | | |
|--------------|----------------------------------|-----|--------------------------------|------|-----------------------------------|------|----------------------------------|-----|---------------------------------|------|-------------------------------|-----|-----|------|--------------------------------|------|-------------------------------|-----|
| | | | A | | B | | C | | D | | E | | F | | BOLT CIRCLE | | BOLT HOLE | |
| | | | in. | mm. | in. | mm. | in. | mm. | in. | mm. | in. | mm. | in. | mm. | in. | mm. | in. | mm. |
| 13F3-C | 4 | 102 | 32 | 813 | 127 ¹ / ₄ | 3232 | 12 ³ / ₄ | 324 | 87 ¹ / ₂ | 2222 | 6 | 152 | 30 | 762 | 27 ³ / ₈ | 695 | 7 ⁷ / ₈ | 22 |
| 24F3-C | 4 | 102 | 42 ³ / ₄ | 1086 | 134 ³ / ₁₆ | 3408 | 16 ³ / ₄ | 425 | 90 ⁷ / ₁₆ | 2297 | 6 | 152 | 30 | 762 | 36 ¹ / ₂ | 927 | 7 ⁷ / ₈ | 22 |
| 31F3-C | 6 | 152 | 48 ³ / ₄ | 1238 | 141 | 3581 | 18 ³ / ₄ | 476 | 95 | 2413 | 7 ¹ / ₂ | 191 | 47 | 1194 | 40 ¹ / ₄ | 1022 | 1 ¹ / ₈ | 29 |
| 40F3-C | 6 | 152 | 54 ³ / ₄ | 1391 | 145 ⁵ / ₁₆ | 3691 | 20 ¹³ / ₁₆ | 529 | 97 ¹ / ₄ | 2470 | 7 ¹ / ₂ | 191 | 43 | 1092 | 50 | 1270 | 1 ¹ / ₈ | 29 |
| 50F3-C | 8 | 203 | 60 ³ / ₄ | 1543 | 152 ¹¹ / ₁₆ | 3878 | 23 ¹ / ₄ | 591 | 102 ³ / ₄ | 2610 | 9 | 229 | 55 | 1397 | 52 | 1321 | 1 ¹ / ₈ | 29 |
| 60F3-C | 8 | 203 | 67 | 1702 | 154 ³ / ₄ | 3931 | 25 ³ / ₈ | 645 | 102 ³ / ₄ | 2610 | 9 | 229 | 60 | 1524 | 52 | 1321 | 1 ¹ / ₈ | 29 |
| 67F3-C | 8 | 203 | 73 | 1854 | 158 | 4013 | 27 ⁵ / ₈ | 702 | 104 | 2642 | 9 | 229 | 62 | 1574 | 56 | 1422 | 1 ¹ / ₈ | 29 |

All dimensions are approximate and should be used for estimating purposes only.

NOTES:

1. Housing model number will include cartridge model number when selected.
2. Clay treater housings use Facet bag or canister style cartridges, 3 deep per stack.
3. Clay cartridges are **not** installed at factory prior to shipment.
4. Removable bundle design available on request. Contact your Facet Representative for details.

Due to our continuing program of improvement, specifications are subject to change without notice.